

32" High-Bright Medical Display

FS-L3202D

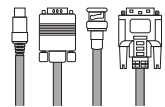

FSN's 32 inch HD medical-grade monitor features a large viewing area, yet is within the requirements of most boom mounting systems. Picture-in-picture or picture-by-picture screen layouts can be fully adjusted for size and position, giving surgeons the flexibility to work with video images tailored to their preference. FS-L3202D is designed without an internal fan. This eliminates the spread of contaminants and makes the monitor perfectly suited for the sterile field in an operating room.



Input & Output Selection

FS-L3202D comes standard with extensive compatibility already built in. Connections are available for a vast array of video signals (digital and analog) including DVI-D, 3G-SDI, SOG, VGA, C-Video, S-Video, and Component. This means that it can adapt to different applications without having to buy extra equipment.



Source Compatibility

With a full range of signal timing tables, FS-L3202D offers ultra-fast video signal detection.

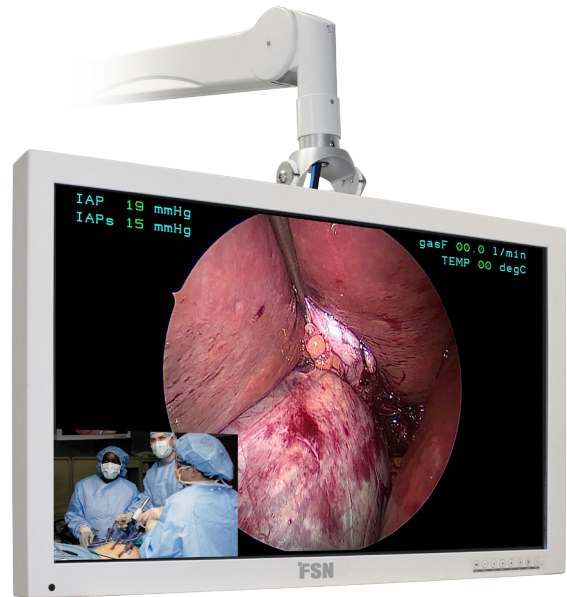

This monitor offers superior color reproduction, and displays exact visualization of critical anatomy being captured by the camera. It provides surgeons with the images needed for multi-specialty procedures, all while being compatible with all popular endoscopy systems.



Attention to Detail

This unit comes with design enhancements that improve workflow in a medical operating room environment. A handheld remote control is included. DC power is available near the video in/out connections to support smaller components such as fiber optic receivers. FS-L3202D reduces cable clutter with its back cover attachment.

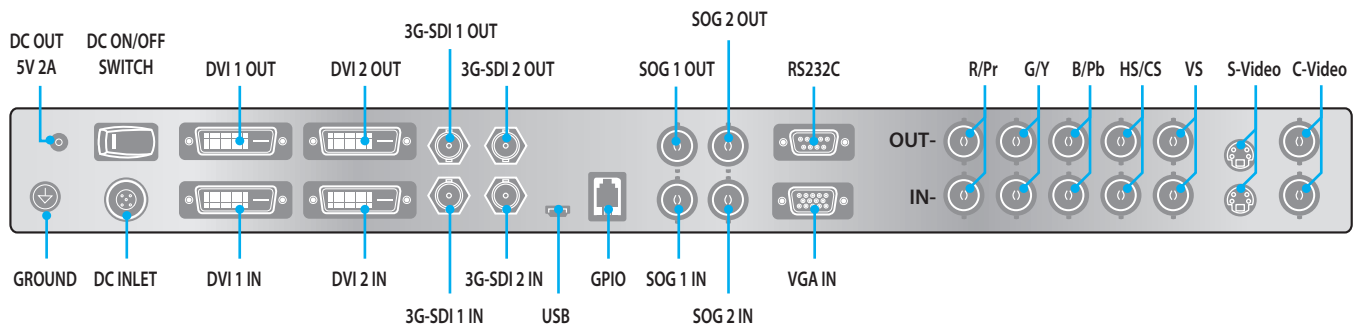

www.fsnmed.com

Foreeseon Custom Displays, Inc.
2210 E. Winston Road
Anaheim, CA 92806 USA
Tel: 714-300-0540
Fax: 714-300-0546

San Jose, CA Tel: 714-507-3851
Fort Lee, NJ Tel: 714-507-3852

Foreeseon Korea
404B, PangyoInnovalley B
253 Pangyo-ro
Bundang-gu Seongnam-si
Gyeonggi-do, Korea 463-400
Tel: +82-31-8018-0780
Fax: +82-31-8018-0786

Foreeseon GmbH
Industriestrasse 38a
63150 Heusenstamm, Germany
Tel: +49 6104 64398 0
Fax: +49 6104 64398 11

Foreeseon UK Ltd.
Unit 71 Barwell Business Park
Leatherhead Road
Chessington, Surrey KT9 2NY
Tel: +44 (0) 208 546 1047

Foreeseon (Shanghai)
Medical Equipment Co., Ltd.
Room 307, 3F
No. 56, 461 Hongcao Road
Caohejing Development District
Xuhui, Shanghai 200233
Tel: 86-21-6113-4188

32" High-Bright Medical Display

FS-L3202D



Specifications

General Features

Item	Description
Panel	32 inch TFT LCD (LED)
Resolution	1920 x 1080 pixel
Aspect Ratio	16 : 9
Active Area	698.4(H)mm x 392.9(V)mm
Pixel Pitch (mm)	0.36375 x 0.36375
Response Time (typical)	25 ms (gray to gray)
Number of Colors	16.7 Million
Brightness (typical)	450 cd/m ²
Contrast Ratio (typical)	1300 : 1
Surface Treatment	Anti-glare
Viewing Angle (CR>10)	R/L 178°, U/D 178°
Input Signal	2 x DVI-D
	2 x SD/HD/3G-SDI (BNC)
	2 x SOG
	1 x VGA (D-sub)
	1 x C-Video (BNC)
Input Signal	1 x S-Video (DIN)
	1 x Component (RGBS, YPbPr) (5 x BNC)

Item	Description
Output Signal	2 x DVI-D
	2 x SD/HD/3G-SDI (BNC)
	2 x SOG
	1 x C-Video (BNC)
	1 x S-Video (DIN)
Output Signal	1 x Component (RGBS, YPbPr) (5 x BNC)
Power Supply	AC/DC Adaptor (AC 100-240V~, DC 24V 6.25A)
Power Consumption	75W max.
Accessories Included	User manual, AC-DC adaptor, AC power cord, DVI-D cable, BNC cable, Remote control, Screw BH M4 x 14
Unit Dimension	770(W) x 471.5(H) x 80.5(D) mm 30.31(W) x 18.56(H) x 3.17(D) inch
Package Dimension	911.35(W) x 742.95(H) x 234.95(D) mm 35.88(W) x 29.25(H) x 9.25(D) inch
IP Rating	IPX1
Weight	13.18 kg, 29.06 lbs. (monitor with cover) 19.14 kg, 42.2 lbs. (shipping package)
Certifications	ANSI/AAMI ES60601-1(UL60601-1), CAN/CSA C22.2 No. 60601-1, FCC Class B, EN60601-1, EN60601-1-2, CE, MDD(93/42/EEC) Class I Medical Device

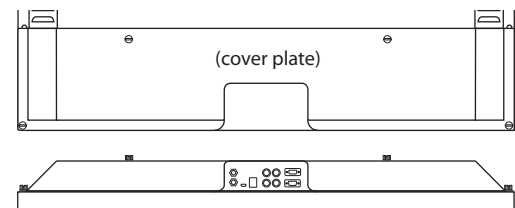
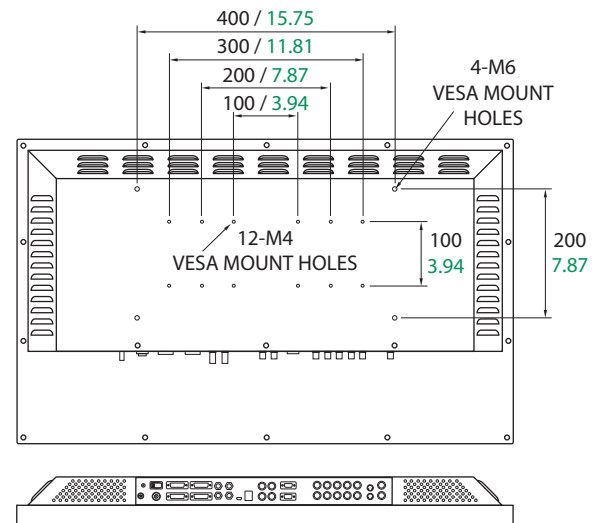
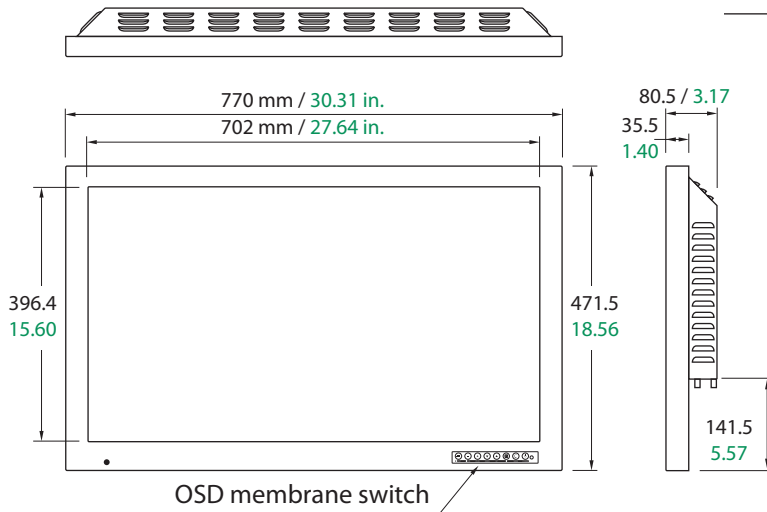

FSN Medical Technologies products meet RoHS2 and Registration, Evaluation, Authorisation and Restriction of Chemicals (REACH) obligations. FSN manages the information flow as required by regulations.

Specifications are subject to change with or without notice. Doc.# FSN1955 Rev. 10/18

www.fsnmed.com

Foreseeson Custom Displays, Inc.
2210 E. Winston Road
Anaheim, CA 92806 USA
Tel: 714-300-0540
Fax: 714-300-0546

San Jose, CA Tel: 714-507-3851
Fort Lee, NJ Tel: 714-507-3852

Foreseeson Korea
404B, PangyoInnovalley B
253 Pangyo-ro
Bundang-gu Seongnam-si
Gyeonggi-do, Korea 463-400
Tel: +82-31-8018-0780
Fax: +82-31-8018-0786

Foreseeson GmbH
Industriestrasse 38a
63150 Heusenstamm, Germany
Tel: +49 6104 64398 0
Fax: +49 6104 64398 11

Foreseeson UK Ltd.
Unit 71 Barwell Business Park
Leatherhead Road
Chessington, Surrey KT9 2NY
Tel: +44 (0) 208 546 1047

Foreseeson (Shanghai)
Medical Equipment Co., Ltd.
Room 307, 3F
No. 56, 461 Hongcao Road
Caohejing Development District
Xuhui, Shanghai 200233
Tel: 86-21-6113-4188